

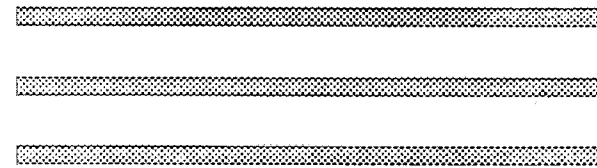

# *HK680*

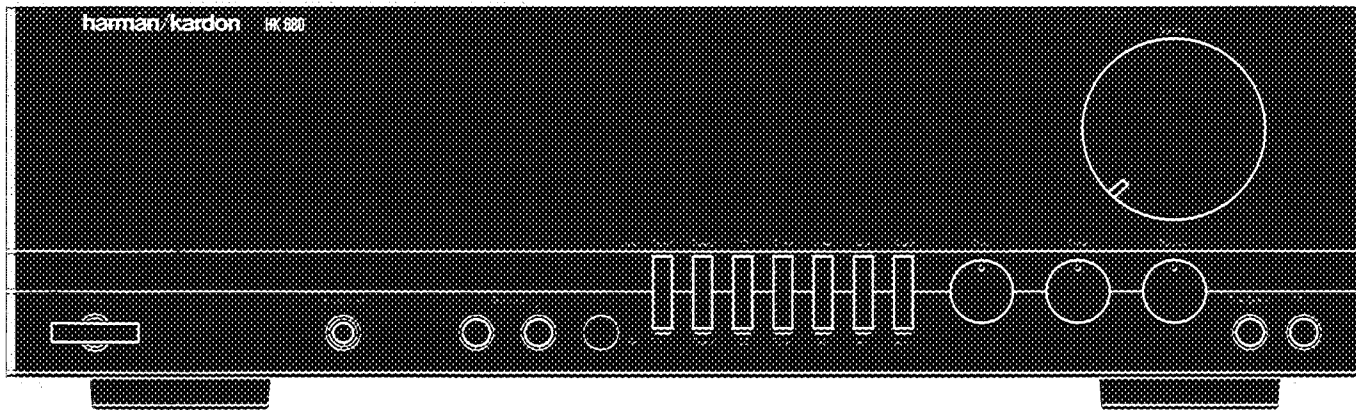

 **harman/kardon**

Integrated Amplifier

**OWNER'S MANUAL**



# HK680 OWNER'S MANUAL

Congratulations on your choice of the Harman Kardon Integrated Amplifier.

In order to obtain the best performance from this integrated amplifier, please be sure to read this owner's manual and use your integrated amplifier only in accordance with its instructions.

The special features of this unit include:

## HCC (High Instantaneous Current Capability)

The amplifier sections react rapidly to musical transients, providing the instantaneous current necessary to precisely drive and control nearly any loudspeaker system.

## Ultrawide Bandwidth

The bandwidth of this unit is exceptionally wide and is independent of negative feedback. This improves transient accuracy and phase linearity.

## Low Negative Feedback

This unit has been designed to have low distortion and wide bandwidth without high negative feedback. This further improves its dynamic accuracy.

## Discrete Component Circuitry

In order to achieve the above goals, all discrete electronic circuitry has been employed. No available integrated circuits could provide this high level of performance.

## Sophisticated Electronic Protection Circuitry

Harman Kardon's unique protection circuitry guards the amplifier from short-circuited or damaged speakers and wires, without impairing sound quality by the use of current limiting or output relays.

## GENERAL INSTRUCTIONS

### Always Use at 230V AC

This unit is designed for operation with 230V AC. Use only domestic AC outlets. Never connect the unit to an outlet supplying a higher voltage. This may create a fire hazard.

### Handle the Power Cord Gently

Do not disconnect the plug from the AC outlet by pulling the cord; always pull the plug itself. Pulling the cord may damage it. If you do not intend to use your unit for any considerable length of time, disconnect the plug from the AC outlet. Do not place furniture or other heavy objects on the cord, and try to avoid dropping heavy objects upon it. Also do not make a knot in the power cord. Not only may the cord be damaged, it can also cause a short circuit with a consequent fire hazard.

## Place of Installation

Place the unit on a firm and level surface. Avoid installing your unit under the following conditions:

- Moist or humid places.
- Places exposed to direct sunlight or close to heating equipment.
- Extremely cold locations.
- Places subject to excessive vibration or dust.
- Poorly ventilated places.

Do not obstruct the ventilation slots on the top surface of the unit by placing objects over them.

Otherwise, the temperature inside the unit may rise, possibly affecting its long-term reliability.

## Do Not Open the Cabinet

To prevent shock hazard, do not tamper with internal components for inspection or maintenance. Harman Kardon does not guarantee against performance degradation resulting from any modification. If water, a hairpin or wire accidentally enters the unit, immediately extract the plug from the AC outlet to prevent shock and consult an authorized Harman Kardon service station. If you use the unit under this condition, it may cause a fire or shock hazard.

## In Case of Moving the Unit

Before moving the unit, be sure to pull out the power cord from the AC outlet and disconnect the interconnection cords with other units.

## Abnormal Smells

If you detect an abnormal smell or smoke, immediately turn the amplifier off and unplug the power cord. Contact your dealer or nearest Harman Kardon service center.

## Cleaning

If the unit gets dirty, wipe it with a soft dry cloth. If necessary, wipe it with a soft cloth dampened with mild soapy water and then with a dry cloth. Never use benzene, thinner, alcohol or other volatile agent, and avoid spraying an insecticide near the unit.

## Packaging

Save all packing material. It is essential for shipping should you move, or in the event the unit ever needs repair.

# CONTROLS and FUNCTIONS

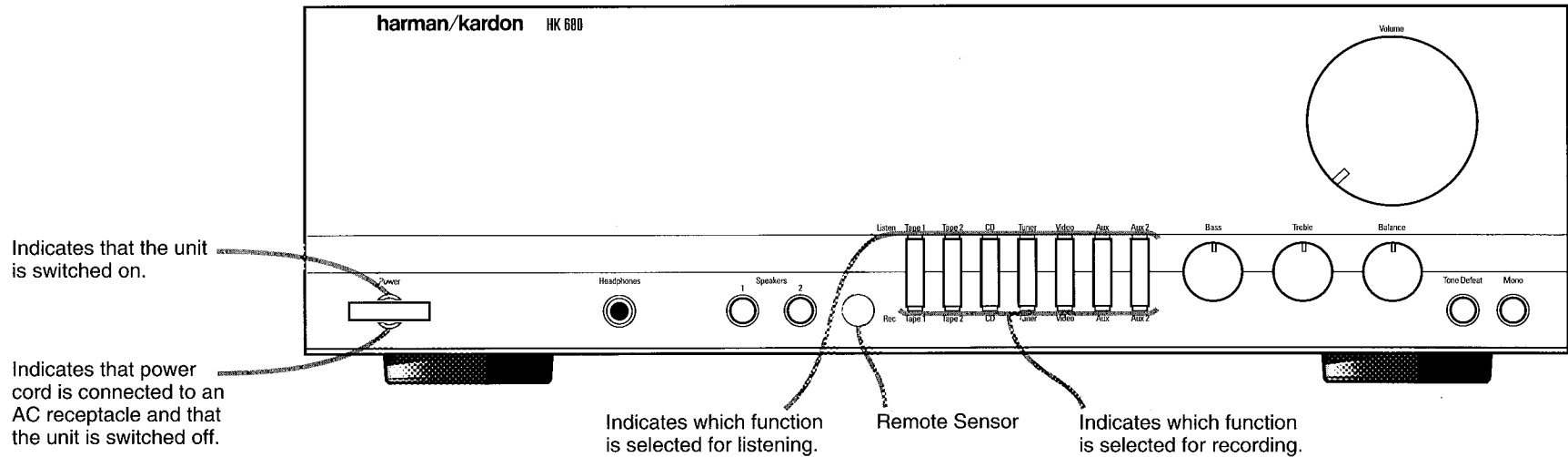

## Power Switch

Press to turn the unit on and off.

## Headphone Jack

Plug in headphones if desired. (With both Speakers 1 and 2 switches in Off position, output is supplied only to headphones.)

## Speakers Switches

Push in to select either of two sets of speakers, or both, or neither (headphone output only).

## Listen Selector Buttons

Select desired input source by pressing the corresponding button.

## Record Selector Buttons

Select desired output source for recording by pressing the corresponding button.

## Bass Control

Turn to increase or decrease the proportion of low frequency sound.

## Treble Control

Turn to increase or decrease the proportion of high frequency sound.

## Balance Control

Turn to adjust relative output level of left and right speakers.

## Volume Control

Turn to raise or lower output volume.

## Tone Defeat Switch

Press to bypass the bass and treble control circuitry. (The bass and treble controls have no effect.)

## Mono Switch

Press to hear input from any source in mono.

# CONNECTIONS

## Connecting Other Components

1. Make sure your amplifier and other components are turned off.
2. Connect each component's Output jacks to the corresponding Input jacks on the back of your amplifier. Use the white, black or gray plugs to connect Left channel jacks; use the red plugs for Right jacks.

## For Customers with a Turntable

To connect a turntable, an optional Phono board must be installed. This board can be set to MM or MC. With the Phono board installed, however, you cannot use the AUX 2 input. If you want to have the Phono board installed, consult your authorized Harman Kardon service center.

## Connecting an external power amplifier

If you want to use your HK680 simply as a preamplifier and connect it to an external power amplifier, use the PRE-OUT connectors in the lower-left corner. Connect the patch cord from the PRE-OUT jacks on the HK680 to the jacks on your external power amplifier. Then connect your speakers to your external power amplifier.

## Connecting an external preamplifier

To use the HK680 simply as a power amplifier, connect the Pre-Out jacks of the external preamplifier to the MAIN-IN jacks on the back panel of the HK680.

Then set the "INTEGRATED-SEPARATE" switch on the back panel to the "SEPARATE" position.

## Wired Remote Control

To control your amplifier with an external infrared remote sensor, connect the wire from the remote sensor to the REMOTE IN jack on the back panel. Or, if another stereo component has a built-in infrared remote sensor and a Remote Output jack, it may be possible to connect this jack to the REMOTE IN jack of your amplifier. All Harman Kardon products with "Remote In" and "Remote Out" jacks are compatible with one another, except for the Citation 22, 24 and 25. Other manufacturers' remote sensors and components may not be compatible, but it will not hurt to experiment.

A second wire may be used to connect your amplifier's REMOTE OUT jack to the Remote Input of another stereo component. Continue this process to include additional components (if compatible).

## Connecting Speakers

1. For best performance, use high quality speaker cables. However, ordinary copper wire can be used if the gauge meets the following requirements:

Wire Length	Gauge
Up to 2.5 meter	18 AWG
Up to 4 meter	16 AWG
Up to 6 meter	14 AWG
Over 6 meter	10-12 AWG custom speaker cable

2. Avoid coiling excess wire with or near line level hook-up cords.

**IMPORTANT:** When connecting two pairs of speakers, determine the impedance of each pair by looking on the back of the speakers, or in your owner's manual, or by contacting your dealer or manufacturer. Then refer to the following chart to see if both sets may be played simultaneously.

If impedance of the two pairs is:	Can both pairs be played simultaneously?
8Ω/8Ω	YES
8Ω/6Ω	NO
8Ω/4Ω	NO
6Ω/6Ω	NO
6Ω/4Ω	NO
4Ω/4Ω	NO

**WARNING:** Do not play both sets of speakers simultaneously except as recommended above. Amplifier may overheat.

## AC Power

Plug the cord into a wall socket (230V AC).

**NOTE:** The power does not shut off completely by just turning the power off. So power cord should be removed from AC outlet when not in use for a prolonged time.

## For Customers in the UK

Your unit is supplied with the flex which will have either two or three wires, so the following items should be observed to guarantee safety:

### THREE CORE FLEX

**WARNING:** THIS APPARATUS MUST BE EARTHED.

**IMPORTANT.** The wires in this mains lead are coloured in accordance with the following code:

Green-and-yellow	: Earth
Blue	: Neutral
Brown	: Live

As the colours of the wires in the mains lead of this apparatus may not correspond with the coloured markings identifying the terminals in your plug, proceed as follows:

The wire which is coloured green-and-yellow must be connected to the terminal in the plug which is marked by the letter E or by the safety earth symbol  or coloured green or green-and-yellow.

The wire which is coloured blue must be connected to the terminal which is marked with the letter N or coloured black.

The wire which is coloured brown must be connected to the terminal which is marked with the letter L or coloured red.

### TWO CORE FLEX

**IMPORTANT.** The wires in this mains lead are coloured in accordance with the following code:

Blue	: Neutral
Brown	: Live

As the colours of the wires in the mains lead of this apparatus may not correspond with the coloured markings identifying the terminals in your plug, proceed as follows:

The wire which is coloured blue must be connected to the terminal which is marked with the letter N or coloured black.

The wire which is coloured brown must be connected to the terminal which is marked with the letter L or coloured red.

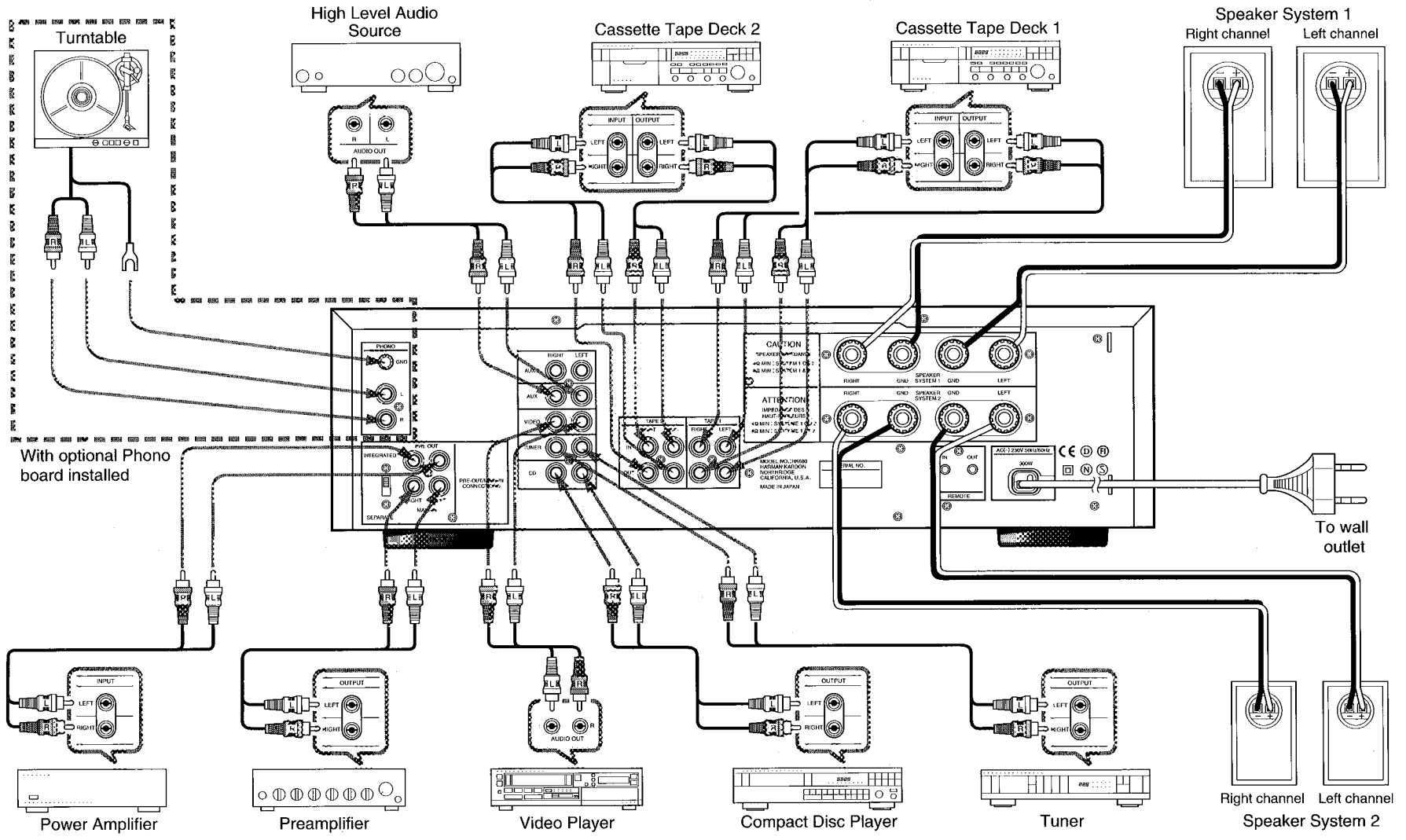

# OPERATING INSTRUCTIONS

## Listening to your CD player, tape deck, tuner or other component sound source

1. Turn Volume control to minimum level and press the Power switch to turn on the amplifier. The power indicator lights up.
2. Set the Speakers switches to play speakers 1, 2, both or neither (for headphone use).
3. Press the Listen selector button corresponding to the component you wish to hear.
4. Begin playing the desired components.
5. Adjust the Volume control to the desired level.
6. Adjust Bass, Treble and Balance controls as desired.

NOTE: If you have the optional Phono board installed, press the Aux 2 button to listen to the turntable.

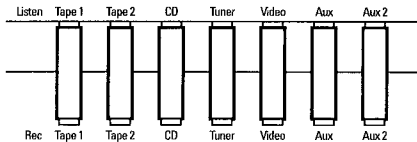

## Making a Recording

To make a recording on a tape deck, simply press the Rec selector button that corresponds to the piece of equipment you wish to record from. The Rec output will be supplied to Tape 1 and Tape 2, enabling you to record on any, or both simultaneously.

- (a) To record from one tape device to another, press the Rec selector button corresponding to the "Rec From" (play) device.
- (b) By selecting different sources for Listen and Rec, you may listen to one audio, while recording from another.

NOTE 1: If a 3-head tape deck is connected to TAPE 1 or TAPE 2 jacks, you can monitor the actual recording while it is in process. Press Listen selector button that corresponds to the connected jack.

NOTE 2: The record output signal is carried directly from the program source without being influenced by the Volume, Bass, Treble or Balance control.

## Independent Remote Control

The keys on the remote control unit function the same as the corresponding buttons on the amplifier itself.

The remote control unit also includes many keys that allow for easy control of other Harman Kardon cassette tape deck, CD player and tuner.

Please refer to the owner's manual for each unit for operating instructions.

Some of these units must be connected to the amplifier's remote control output jacks so that the system remote control can operate them.

## Operating Conditions

The control unit operates effectively within a distance of 7 meters and an angle of 30° from the amplifier. Using the control near fluorescent lights may shorten this range, as will any dust or dirt that accumulates on the front of the remote control, or the remote sensor area of the amplifier. Also avoid blocking the line of sight between amplifier and remote.

The control unit is powered by two AA batteries, included with your amplifier. When you replace weak batteries, replace both at the same time. When the remote is to be unused for an extended period, remove the batteries to prevent damage from corrosion.

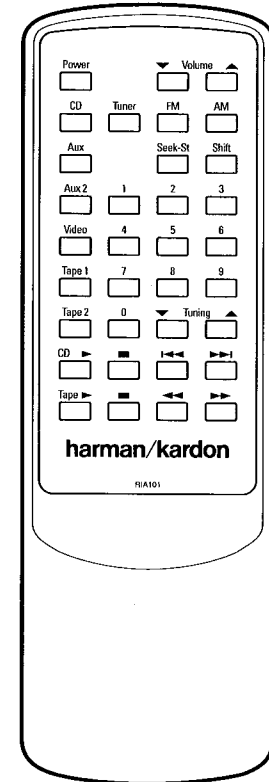

# TROUBLESHOOTING

This unit is designed for trouble-free operation; most problems users encounter are due to operating errors. So if you have a problem, first check this list for a possible solution. If the problem persists, consult your authorized Harman Kardon service center.

## If the problem is:

## Make sure that:

No lights illuminate when power cord is plugged into AC outlet.

- The unit is plugged into a live outlet.

No sound is heard.

- Press the Speakers switches corresponding to the desired speakers.
- Correct Listen button has been pressed.
- Volume is turned up.
- Speaker wires are connected properly.
- Hook-up wires to source component are connected properly.

Sound is not heard from the speaker system on one side.

- The speaker wires and connection wires are connected correctly.
- The balance control knob is set to the center.

When listening to stereo sound, the left and right sounds are reversed.

- The speaker wires are connected correctly.
- The wires between components are connected correctly.

Intermittent or continuous buzzing or hissing.

- The unit is away from fluorescent lights, TVs, motors and other electrical appliances.

Tone control is not functioning.

- Press the Tone Defeat switch to off position.

Phono sound is too faint, has hum, ringing, or "howl".

- Ground wire from turntable has been connected to ground terminal on amplifier.
- Cable from turntable is away from power cords and speaker cables.
- Turntable is away from speakers.
- Turntable is on stable surface.

Note: The optional phono board is required to play a turntable.

# SPECIFICATIONS

Continuous Average Power Per Channel (FTC) 20Hz - 20kHz, Both Channels Driven	8 Ohms:	85 Watts @ <0.08%THD
	4 Ohms:	130 Watts @ <0.3%THD
Dynamic Power (IHF, 1kHz tone burst)	8 Ohms:	110 Watts
	4 Ohms:	170 Watts
	2 Ohms:	240 Watts
High Instantaneous Current Capability (HCC):		±70 Amps
Power Bandwidth @ half-rated output, 8Ω:		<10Hz - 100kHz
Frequency Response @ 1W (+0/-3dB):		0.25Hz - 100kHz
Damping Factor:		80
Signal-to-Noise Ratio (reference rated power output, A-Wtd.)	Tuner/CD:	98dB
	Option Phono (MM):	80dB
	Option Phono (MC):	75dB
Input Sensitivity/Impedance	Tuner/CD:	150mV/22kΩ
	Option Phono (MM):	2.2mV/47kΩ, 125pf
	Option Phono (MC):	120μV/56Ω
Phono-Overload	Option Phono (MM):	100mV
	Option Phono (MC):	5mV
Tone Control Range, Bass @ 50Hz/Treble @ 10kHz:		±10dB/±10dB
Power Supply:		AC 230V, 50/60Hz
Power Consumption:		300W
Dimensions (Width × Height × Depth):		443 × 134 × 406mm
Weight:		12.4kg

All features and specifications are subject to change without notice.

## Declaration of Conformity



We, Harman Marketing Europe a/s  
Kongevejen 194B  
DK-3460 Birkerød  
DENMARK

declare in own responsibility, that the  
product described in this owners  
manual is in compliance with technical  
standards:

EN 55013/6.1990, EN 55020/6.1988,  
EN 55022/4.1987

Accredited test laboratory:  
MIKES PRODUCT SERVICE GmbH  
Ohmstrasse 2-4  
D-94342 Strasskirchen

Birkerød, DENMARK, Oct. 18. 1994

Steen Michaelsen  
**harman** marketing europe a/s

*The appliance conforms with EEC directive  
87/308/EEC regarding interference  
suppression.*